

INSTRUCTION MANUAL

PORTABLE DOUBLE ACTION HYDRAULIC PUNCHER

Please read this manual carefully before you attempt to use your tool so that you may use it properly and safely.

SELFER ACE

Model HS06-1322, HS07-1624, HS11-1624

PROFESSIONAL TOOL

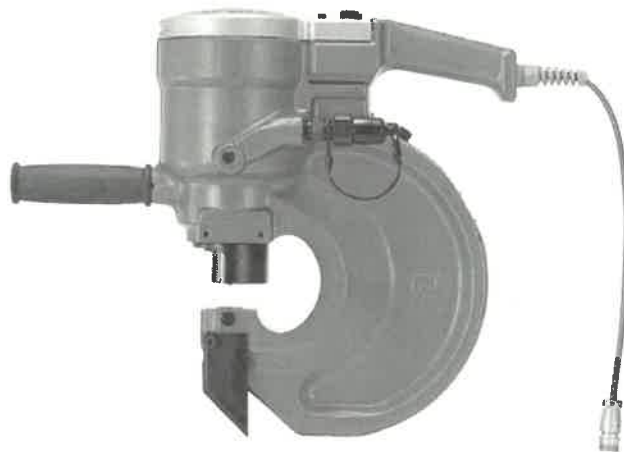

Specifications

Model		HS06-1322	HS07-1624	HS11-1624	
Max. Throat Depth		60mm	70mm	110mm	
Punching Capacity	Max. Punching Thickness	Mild Steel	13mm	16mm	16mm
		Stainless Steel	6mm	6mm	6mm
	Max. Punching Diameter	22mm	24mm	24mm	
Hole Making Time * (Pump:HPD-05)		7.9sec	11.8sec	11.8sec	
Allowable max. pressure		68.65MPa			
Max. Output		357KN	464KN	464KN	
Ram Stroke		21mm	25mm	25mm	
Mass (Weight)		20.5Kg	25.5Kg	30Kg	

*The Hole Making Time may be varied by the hydraulic oil temperature at the time of operation.

Due to continuous product development/improvement the specifications and configurations in this manual may be subject to change without prior notice.



HAJO TOOL

PROFESSIONELT SPECIALVÆRKTØJ

Vejlegårdsvej 65 B • DK-2665 Vallensbæk
Telefon +45 4444 2400 • Fax +45 4444 0833
www.hajo.dk • hajo@hajo.dk



Manufactured by :

NITTO KOHKI Co., Ltd.
2-9-4, Nakaikegami, Ohta-ku,
Tokyo, 146-8555, Japan
TEL : (81)-3-3755-1111
FAX : (81)-3-3753-8791
E-mail : overseas@nitto-kohki.co.jp
URL : www.nitto-kohki.co.jp

Keep the manual handy – so you can use it whenever necessary.

Original Instructions

Thank you very much for your purchase of this **Nitto Kohki products**.

Before using your tool, please read this manual carefully so that you may use it properly to get the most out of it.

Please keep the manual handy - so you can use it whenever necessary.

- **English** : Please ask your dealer or distributor for instruction manual in local language(s).
- **German** : Bitte fragen Sie Ihren Händler nach eine Betriebsanleitung in Landessprache.
- **French** : S'il vous plait, veuillez demandez à votre fournisseur de manuel instruction en langue locale.
- **Spanish** : Por favor, contacte con su distribuidor para el manual de instrucciones en español.
- **Portuguese** : Por favor pessa ao seo agente ou distribuidor o manual de instrucces ih linguagen local.
- **Italian** : Per Manuale Istruzioni in lingua locale Vi preghiamo di rivolgervi al rivenditore o distributore.
- **Dutch** : Vraag uw handelaar om een nederladstalige gebruiksaanwijzing.
- **Swedish** : Be er lokala Åtreförsäljare eller distributör om manualer på svenska.
- **Danish** : Venligst henvend Dem til den danske distributør for instructions manualer.
- **Polish** : Proszę pytać swojego dealera lub dystrybutora o instrukcje obsługi w języku localnym.
- **中文** : 請向當地供應商或經銷商詢問中文使用說明書

CONTENTS	page
IMPORTANT SAFETY INSTRUCTIONS FOR ALL	
ELECTRIC TOOLS	2
IMPORTANT SAFETY INSTRUCTIONS FOR PORTABLE	
DOUBLE ACTION HYDRAULIC PUNCHERS	3
1. USAGE	4
2. CHECK THE CONTENTS OF THE PACKAGE	4
3. NAME OF PARTS	4
4. PUNCHING CAPACITY	4
5. PREPARATION	5
6. HOW TO OPERATE THE TOOL	6
7. MAINTENANCE AND INSPECTION	7
8. REPLACING THE PUNCH AND DIE	7
9. ORDERING SERVICE PARTS	8
10. HS06-1322 ASSEMBLY	11
11. HS06-1322 PARTS LIST	12
12. HS07-1624, HS11-1624 ASSEMBLY	13
13. HS07-1624, HS11-1624 PARTS LIST	14

PICTOGRAM



Warning: It might be dangerous to operate the tool if the instructions supplied are not followed.



Using this tool improperly could result in serious injury. Read the instruction manual before use.



Always wear suitable eye protection.



Always wear suitable hearing protection.



Always wear respiratory protective equipment (PPE).



Always wear protective gloves for protection of hands from Vibration and Shock

The following Safety notations are used throughout the manual to highlight safety precautions for the user and for the tool.

WARNING:	Indicates a potentially hazardous situation which, if not avoided by following the instructions given, could result in death or serious injury.
CAUTION:	Indicates a potentially hazardous situation which, if not avoided by following the instructions given, could result in injury or material damage.

Please note, however, that failure to observe safety precautions under the “ **Caution**” category could result in a serious occurrence depending on the situation: please observe all safety precautions in the manual.

Caution: Important precautions for tool setup, operation and maintenance.

IMPORTANT SAFETY INSTRUCTIONS FOR ALL ELECTRIC TOOLS

WARNING

When using electric tools, basic safety precautions should always be followed to reduce risk of fire, electric shock, personal injury and the like, including the following.

(1) Keep work area clean.

- Cluttered work areas and benches invite accidents and injuries.

(2) Consider work area environment.

- Do not expose tools to rain. Do not use tools in damp or wet locations.
- Keep work area well lit.
- Do not operate near flammable liquids or in gaseous or explosive atmospheres.

(3) Be cautious about electric shock.

- When using electric tools, do not touch any which is earthed. (Ex. Pipe, heating apparatus, microwave oven, outside frame of refrigerator)

(4) Keep children away.

- Also all visitors should be kept away from work area.
- Do not let visitors contact the tool, compressor or connecting hoses.

(5) Store idle tools.

- When not in use, tools should be stored in dry, and locked-up places out of reach of children.

(6) Do not force tool.

- It will do the job better and safer at the rate which it was designed.

(7) Use right tool.

- Do not force a small tool of attachment to do the job of a heavy-duty tool.
- Do not use tool for a purpose not intended.

(8) Dress properly.

- Do not wear loose clothing or accessories. They can be caught in moving parts.
- Non-skid footwear is recommended.
- Wear protective hair covering to contain long hair.

(9) Always wear eye protection.

- Everyday eyeglasses only have impact resistant lenses. They do not protect eyes. Also use face or dust mask, if operations create dust.

(10) Do not abuse cable.

- Never carry tool by connecting cable or yank on hose to disconnect.
- Do not place a cable near a place with high heat, oil, and sharp edge.

(11) Secure work.

- Use clamps or a vise to hold workpieces when practical. It is safer than using your hand and it frees both hands to operate tool.

(12) Do not overreach.

- Keep proper footing and balance at all times.

(13) Cautious maintenance is necessary for electric tools.

- Always maintain blades and keep it work well so that safe and efficient work can be done.
- Follow the instruction manual for oiling or change of accessories.
- Check the cable regularly. Contact the sales agents to repair it when it is defective.
- When an extension cable is used, check regularly and change it when it is damaged.
- The grip should be kept dry and clean. Maintain it so well that it does not carry oil or grease.

(14) Switch off and take off the plug for the following:

- Not in use.
- When you change blades, grinding stone and bit.
- Any danger is anticipated.

(15) Remove spanners, wrenches etc., after adjustment.

- Make sure that spanners, wrenches etc., which are used for adjustment are removed before switching on.

(16) Always avoid unexpected start.

- Do not carry the tool with a finger on the switch when the power supply is on.
- Make sure that the switch is off before plugging in.

(17) Use a cabtyre cable or a cabtyre extension cable when it is used outside.

IMPORTANT SAFETY INSTRUCTIONS FOR PORTABLE DOUBLE ACTION HYDRAULIC PUNCHERS

(18) Stay alert.

- Watch what you are doing.
- Bear in mind the way of handling/operation and the circumstances of the surrounding area.
- Use common sense.
- Do not operate tool when you are tired.

(19) Check damaged parts.

- Before further use of the tool, an accessory or other part that is damaged should be carefully checked to determine that it will operate properly and perform its intended functions.
- Check for alignment of moving parts, binding of moving parts, breakage of parts, mounting and any other conditions that may affect its operation.
- An accessory or other part that is damaged or inoperable should be properly repaired or replaced. When a switch becomes out of order, repairs should be performed only by the sales agent from whom you purchased the tool or an authorized dealer.
- Do not use electric tools which cannot be activated or stopped with a switch.

(20) Use recommended accessories.

- Consult this manual or the sales agent from whom you purchased the tool an authorized dealer for recommended accessories. The use of improper accessories may cause risk of injury to persons.

(21) Repairs by authorized personnel.

- This tool should not be modified as it meets safety requirements.
- Any repairs to the tool or installation of replacement parts should be performed only by the sales agent from whom you purchased the tool or an authorized dealer.
- Failure to utilize the expertise of the sales agent from whom you purchased the tool or an authorized dealer or, failure to use genuine replacement parts, may result in an increased risk of injury to the user and may invalidate your warranty.

WARNING

- **Use the Nitto Kohki Pump, model HPD-05, for Selser Ace.**
- **Ear protection must be used.**
- **Some tools will emit a loud noise.**
Be sure to check whether you are complying with local noise regulations.
- **Some tools generate substantial vibrations.**
If discomfort or pain is encountered during use, you should cease operations and check with your physician prior to further use.
- **Never touch the moving parts.**
- **Do not leave the tool while it is operating.**
If you leave the workplace, switch off the tool and remove the power plug from the supply. Do not leave the area until the tool comes to a complete stop.
- **Do not remove any labels or name plates from the tool.**
If a label or name plate has been damaged or is missing, contact the sales agent from whom you purchased the tool or an authorized dealer to obtain a replacement.
- **Do not make a hole which exceeds the capacity of the tool.**
A punching diameter or punching plate thickness greater than the rated capacity of the tool not only causes a breakdown but may cause injury if the Punch or Die is broken.
- **Use a Punch and Die with the same nominal diameter.**
Using a Punch and Die with different nominal diameters may cause damage and injury.
- **Fit the Punch and Die properly.**
Incorrect orientation or failure to fit the Punch and Die securely may cause damage and injury.
- **Beware of ejected chips.**
When a hole is made, the chips fly out with great force. This is especially so when working on hard materials such as stainless steel. Make sure the Chip Guard is attached.
- **Do not touch the Punch or Die while the tool is operating.**

1 USAGE

Selfer Ace is a tool which uses a Nitto Kohki Double Action Hydraulic Pump to make holes for bolts or rivets, etc. in shape steel, flat plates, etc.

The pump model which suits this application is HPD-05.

2 CHECK THE CONTENTS OF THE PACKAGE

Check the contents and make sure that the tool does not have any damage due to an accident during the transportation, if any. The contents should correspond to the list as follows. Just in case there are some damages or missing parts, contact the sales agent from whom you purchased the tool or an authorized dealer.

Package contents	Model (C = Check Column)					
	HS06-1322	C	HS07-1624	C	HS11-1624	C
Unit						
Ultra-high Pressure Hose Ass'y	1set		1set		1set	
Hose Cord Ass'y	1set		1set		1set	
Tool Box	1		1		1	
Sub Handle Ass'y	1set		1set		1set	
Chip Guard Ass'y	1set		1set		1set	
Spanner	1		1		1	
Spanner 12	1		1		1	
Hex. Socket Screw Key 4	1		1		1	
Hex. Socket Screw Key 5	1		1		1	
Instruction Manual	1		1		1	
Declaration of Conformity	1		1		1	

3 NAME OF PARTS

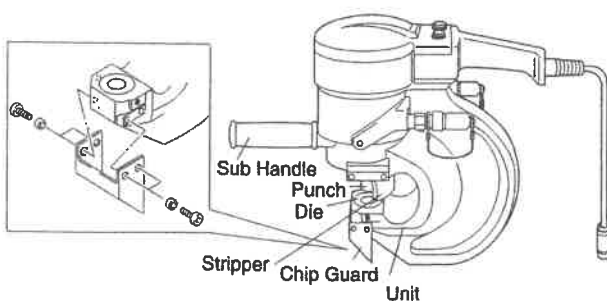

(Fig.1)

4 PUNCHING CAPACITY

Stainless Steel

· For stainless steel, the maximum punching plate thickness is 6 mm.

4-1 MAXIMUM PUNCHING DIAMETER

Maximum punching diameters are standardized on material equivalent to mild steel (tensile strength : 400 ~ 510N/mm²). If other materials are to be used, the following formula can be used to calculate W, the power required to make the hole, which must not exceed the maximum output power for each type of tool.

$$W \geq \frac{\pi \times D \times t \times \sigma \times 0.8}{1000}$$

W : Power required to make the hole (kN)

π : 3.14

D : Punching diameter (mm)

t : Plate thickness (mm)

σ : Material tensile strength (N/mm²)

Model	W
HS06-1322	367kN
HS07-1624	464kN
HS11-1624	464kN

4-2 MAXIMUM PUNCHING PLATE THICKNESS FOR VARIOUS PUNCHING DIAMETERS

The following limitations apply to punching plate thickness based on punching diameters. These should not be exceeded.

Mild Steel : Max. plate thickness
 $\leq 0.8 \times$ punching diameter

Stainless Steel : Max. plate thickness
 $\leq 0.5 \times$ punching diameter

4-3 MINIMUM PUNCHING PITCH

Accurate holes can not be made if the punching pitch is too small. The minimum pitch is given by the following formula.

$$P = 1.5 \times t + D$$

P : Pitch (mm)
D : Punching diameter (mm)
t : Plate thickness (mm)

4-4 HOLE PRECISION

Holes made with this tool are mechanically rough, deformed and distorted. Where precision is required, use the Nitto Kohki Atra Ace Series.

4-5 APPLY OIL FOR EXTENDED PUNCH LIFE

A little oil (machine oil, spindle oil, turbine oil) applied to the Punch will improve its release and extend its life.

5 PREPARATION

5-1 ATTACHING ACCESSORIES

Attach the Sub Handle Ass'y and Chip Guard Ass'y to the Selfer Ace. (Fig. 1)

5-2 HOSE CONNECTIONS

(1) Connect the hoses between the Selfer Ace and the Pump. The 700R Cupla is used on the thrust side (high pressure) and the 450B Cupla goes to the return side (low pressure). Make the connections as follows. (Fig. 2)

To Prevent Malfunction

- Before connecting the Cuplas, ensure they are well cleaned and free of dust and foreign matter.
- After disconnecting the Cupla always fit the supplied dust caps.

[700R]

- ◎ Connection :Align the two — — marks of both sleeves of Cupla, force inwards and once fully depressed rotate Cupla sleeve 90 degrees. This will fully lock the Cupla in position.
- ◎ Disconnection :To disconnect re-align the two — — marks on the Cupla sleeves and the Cupla will disconnect.

[450B]

- ◎ Connect :Align the slot on socket sleeve with the lock pins, draw back the sleeve and push over the plug. Release the sleeve and then rotate the sleeve 90 degrees.
- ◎ Disconnection :To disconnect rotate the sleeve until slot and pins are aligned then simply pull back sleeve.

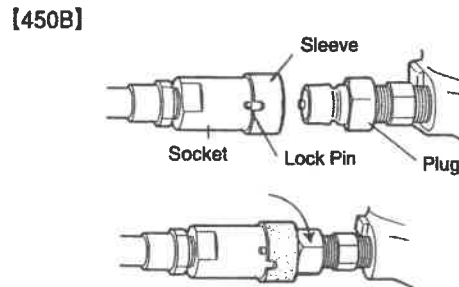
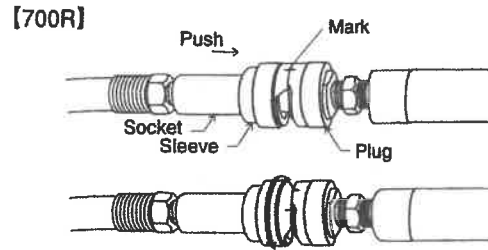

(Fig.2)

(2) Connect the Switch Cord to the Selfer Ace and Pump. (Fig. 3)

(3) Connect the Power Plug which is coming from the Pump to the power source. (Fig.3)

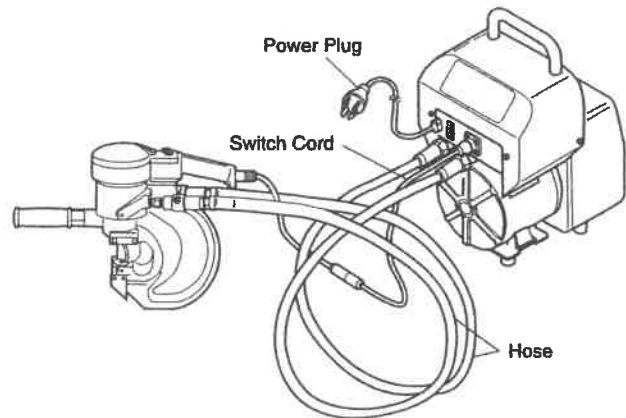

(Fig.3)

6 HOW TO OPERATE THE TOOL

6-1 START AND STOP

⚠ WARNING

- **Don't pressurize the Pump independently.** If the Pump is by itself, or the hoses are not connected to the Selfer Ace, the Pump must not be started. Otherwise the valves may be forced out of the Cuplas.

6-1-1 PUMP

Turn on the Power Supply Switch.

6-1-2 SELFER ACE (FIG. 4)

- (1) The Ram (Punch) will continue to descend while the Descend Switch is pressed and it will stop when the Switch is released.
- (2) When the Descend Switch is kept pressed, the pump stops at the lower dead point.
- (3) The Ram (Punch) will continue to rise while the Raise Switch is pressed and it will stop when the Switch is released.
- (4) When the Raise Switch is kept pressed, the Pump stops at the upper dead point.

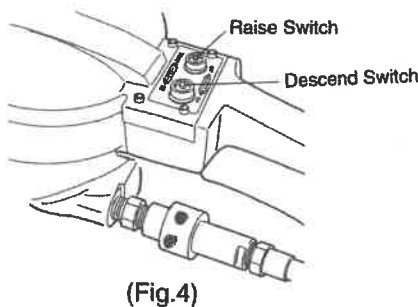

6-2 PUNCHING PROCEDURE

⚠ WARNING

Wear eye protection while working. If much dust is produced, wear a dust mask also.

(1) Make a Punch Mark

Make a large punch mark in the workpiece at the position where the hole is to be made.

(2) Stripper Position

Adjust the Stripper so that its lower edge is level with or slightly lower than the bottom of the cutting face of the Punch. Make sure the Stripper is above the workpiece.

(Fig. 5)

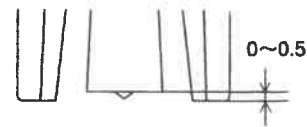

(Fig. 5)

(3) Align the Punch

Align the leading edge of the Punch with the punch mark.

(4) Make the Hole

Press the Descend Switch and start punching the hole.

(5) Making Holes in Tapered Materials

The Stripper may be damaged if tapered workpieces such as I-steel, channel steel, etc., are punched in the normal way. Tapered dies, as shown in Figure 6, are available for this purpose and should be ordered separately.

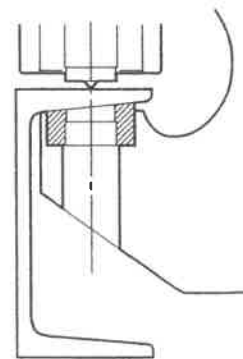

(Fig.6)

7 MAINTENANCE AND INSPECTION

⚠ WARNING

- The Power Plug must be removed from the power supply during maintenance and inspection.
- All attached parts should be checked periodically for loose screws, etc. Any loose screws should be tightened securely.

7-1 OIL CHANGE

Initial oil replacement should be done after operation for fifty hours. Subsequent replacement should be made at intervals of five hundred hours.

7-2 WIRING DIAGRAM AND OIL CIRCUIT DIAGRAM

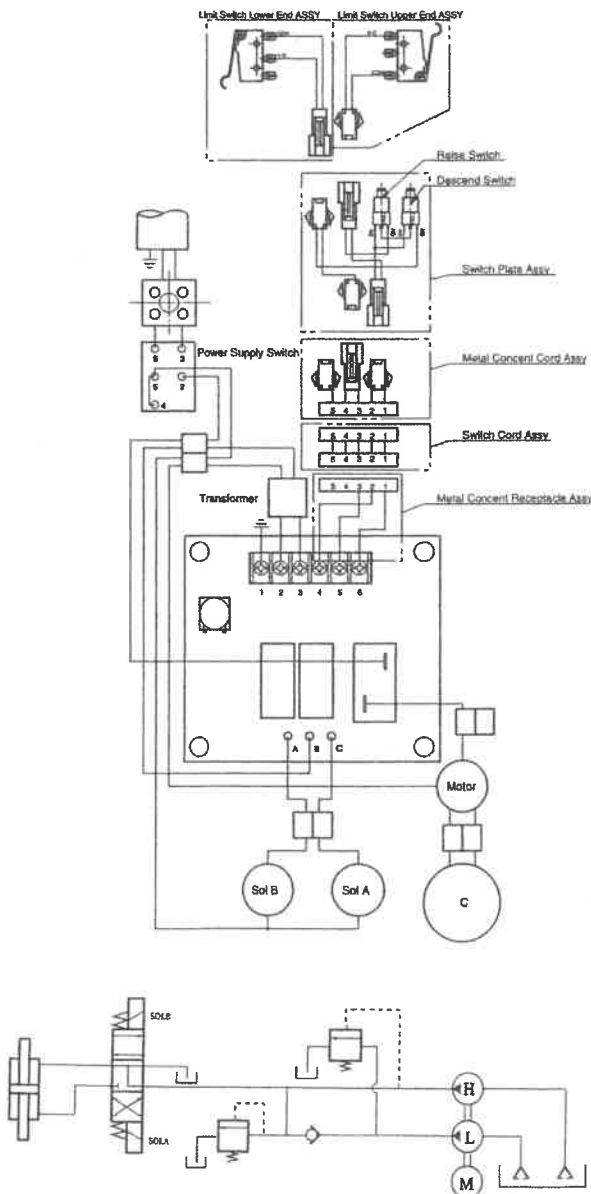

(Fig.7)

8 REPLACING THE PUNCH AND DIE

⚠ WARNING

- When replacing the Punch and Die, be sure to disconnect the Power Plug from power supply.
- Use a Punch and Die with the same nominal diameter.
- Mount the Punch and Die precisely.

8-1 MOUNTING

Notes on mounting

- Mount the Punch, then the Die in that order.
- Lock Nut S Ass'y which is sold separately is required for punches with a punching diameter of more than 24 mm.

Punch

Insert the Punch in the Lock Nut and tighten it securely to the Ram. Tighten the Lock Nut securely so that it can not be turned or shaken by hand. (Fig. 8)

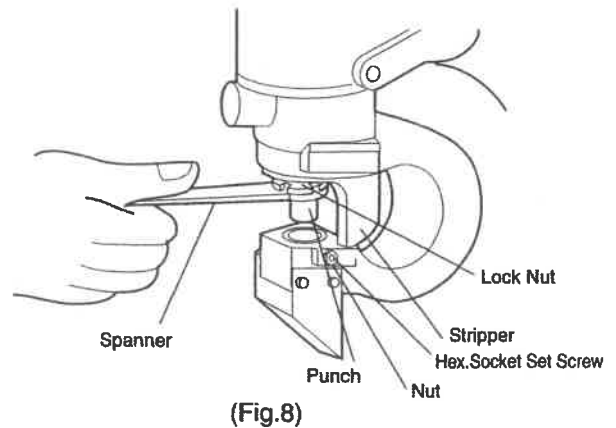

(Fig.8)

Die

(1) Insert the Die in the Frame so that the inscription "Up" is visible. (Fig.9)

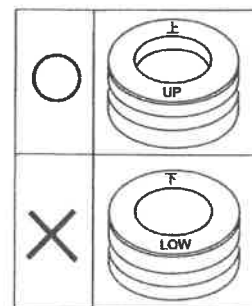

(Fig.9)

(2) If a Die with no Up or Low inscription is used, insert it into the Frame with the cutting edge up.

(3) Tighten the Hex. Socket Set Screws on both sides of the Frame and fix them with nuts.

8-2 REMOVAL

Remove the Die, then the Punch in that order.

8-3 REPLACING SPECIAL-FORMED PUNCH AND DIE Punch

Insert the Punch so that the pin on the head of the Punch enters the pin hole in the Ram.

As shown in Figure 10, the pin hole is on the right side of the Ram. There is also a pin hole 90° around in the clockwise direction.

Die

(1) Insert the Die in the Frame so that the inscription "Up" is visible. (Fig. 10)

(2) If a Die with no Up or Low inscription is used, insert it into the Frame with the cutting edge up.

(3) Align the cavity in the Alignment Jig with the punch cutter then turn the Die so that it aligns with the protruding part of the Alignment Jig.

(4) When the position has been determined, replace the fastening screws on both sides of the unit with Hex. Socket Set Screws with Ball M8 × 14 (TQ01279) which are sold separately, and fix them with nuts. If a Round Hole Die is to be used, the accessory Hex. Socket Set Screws should be restored.

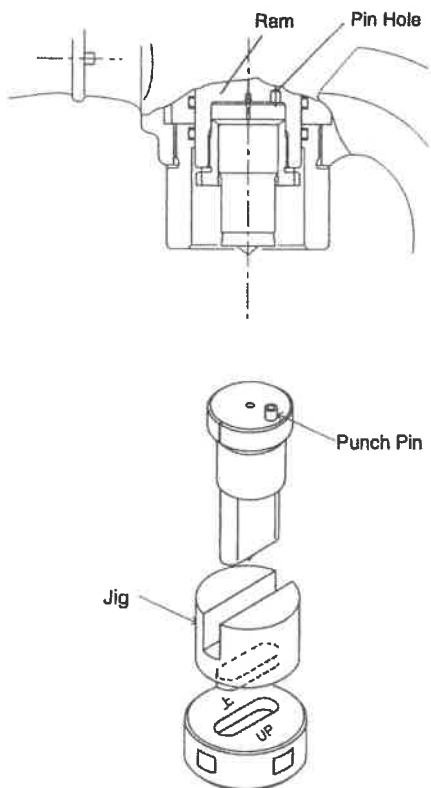

(Fig.10)

9 ORDERING SERVICE PARTS

9-1 OPTIONAL EXTRAS

9-1-1 HOOK CLAMP ASS'Y (TB02142)

A Hook Clamp Ass'y is available for the Selfer Ace and can be ordered separately. This uses the Sub Handle attachment holes (M16 × P1.5) and enables the tool to be slung from a balancer, etc., for work or transportation.

The one Hook Clamp is common to all three Selfer Ace models. (Fig. 12)

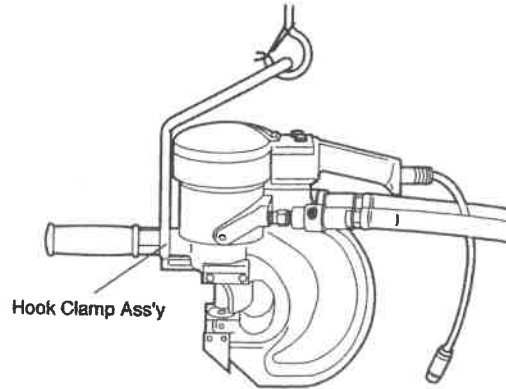

(Fig.12)

9-1-2 PUNCHES AND DIES

Consult the sales agent from whom you purchased the tool or an authorized dealer for sizes other than those shown below.

Round Holes

Part No.	Part Name	Part No.	Part Name
TJ10778	D Punch ϕ 8	TJ10779	D Die ϕ 8
TJ11088	D Punch ϕ 9	TJ11089	D Die ϕ 9
TJ06700	D Punch ϕ 10	TJ06701	D Die ϕ 10
TJ06698	D Punch ϕ 11	TJ06699	D Die ϕ 11
TJ06696	D Punch ϕ 12	TJ06697	D Die ϕ 12
TJ06694	D Punch ϕ 13	TJ06695	D Die ϕ 13
TJ06692	D Punch ϕ 14	TJ06693	D Die ϕ 14
TJ06611	D Punch ϕ 14.5	TJ06612	D Die ϕ 14.5
TJ06690	D Punch ϕ 15	TJ06691	D Die ϕ 15
TJ06688	D Punch ϕ 16	TJ06689	D Die ϕ 16
TJ06686	D Punch ϕ 17	TJ06687	D Die ϕ 17
TJ06609	D Punch ϕ 17.5	TJ06610	D Die ϕ 17.5
TJ06684	D Punch ϕ 18	TJ06685	D Die ϕ 18
TJ06682	D Punch ϕ 19	TJ06683	D Die ϕ 19
TJ06680	D Punch ϕ 20	TJ06681	D Die ϕ 20
TJ06607	D Punch ϕ 20.5	TJ06608	D Die ϕ 20.5
TJ06678	D Punch ϕ 21	TJ06679	D Die ϕ 21
TJ07979	D Punch ϕ 21.5	TJ07980	D Die ϕ 21.5
TJ06676	D Punch ϕ 22	TJ06677	D Die ϕ 22
TJ06674	D Punch ϕ 23	TJ06675	D Die ϕ 23
TJ06566	D Punch ϕ 23.5	TJ06569	D Die ϕ 23.5
TJ07748	D Punch ϕ 24	TJ07749	D Die ϕ 24
TJ10061	D Punch ϕ 25	TJ10062	D Die ϕ 25

Elongated Holes

Part No.	Part Name	Part No.	Part Name	Part No.	Part Name
TJ13229	D Punch 16 × 8	TJ13238	D Die 16 × 8	TK00455	Alignment Jig 16 × 8
TJ13230	D Punch 18 × 9	TJ13239	D Die 18 × 9	TK00456	Alignment Jig 18 × 9
TJ13231	D Punch 20 × 10	TJ13240	D Die 20 × 10	TK00457	Alignment Jig 20 × 10
TJ13232	D Punch 22 × 11	TJ13241	D Die 22 × 11	TK00458	Alignment Jig 22 × 11
TJ13233	D Punch 24 × 12	TJ13242	D Die 24 × 12	TK00459	Alignment Jig 24 × 12
TJ13234	D Punch 25 × 9	TJ13243	D Die 25 × 9	TK00460	Alignment Jig 25 × 9
TJ13235	D Punch 25 × 12	TJ13244	D Die 25 × 12	TK00461	Alignment Jig 25 × 12
TJ13236	D Punch 25 × 14	TJ13245	D Die 25 × 14	TK00462	Alignment Jig 25 × 14
TJ13237	D Punch 25 × 18	TJ13246	D Die 25 × 18	TK00463	Alignment Jig 25 × 18

Lock Nut S Ass'y (TA99037) is required for Punches with 25 mm punching diameter.

9-2 ORDERING PARTS

In ordering parts and components from the sales agent from whom you purchased the tool or an authorized dealer, give each part number, part name and quantity required.

10 HS06-1322 ASSEMBLY

⚠ WARNING

This diagram is for your reference only. Do not attempt to service or repair the Tool.
Do not take the Tool apart. Contact an authorized Nitto dealer for all service and repair of the Tool.
Improper service and repair can cause accidents and service injuries.
Never attempt to modify the Tool.
Never attempt service or repair the Tool yourself.

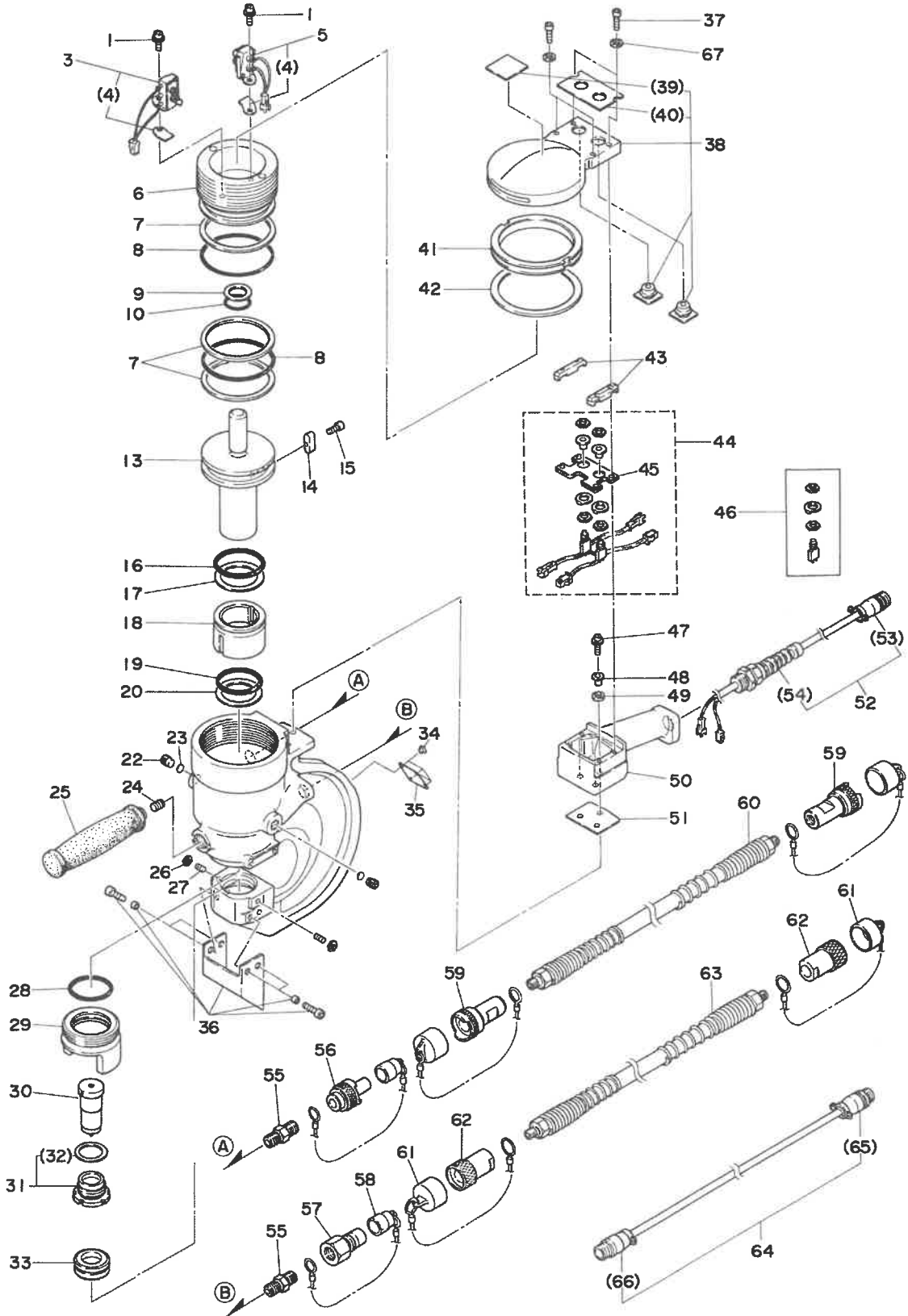

11 HS06-1322 PARTS LIST

The part numbers with () are included in the Ass'y parts written above them.

No.	Parts No.	Description	Qty	Price
1	TQ03336	Hex. Socket Head Cap Screw with spring washer 6 × 12	2	
3	TB02286	Limit Switch Lower End Ass'y	1set	
4	(TQ02047) (TQ02048)	Shim 1.0 (for Adjustment) Shim 0.5 (for Adjustment)		
5	TB04857	Limit Switch Upper End Ass'y	1set	
6	TQ02067	Cap	1	
7	TQ02068	Back-up Ring P-75 T3	3	
8	TQ02065	O-Ring P-75 PUR	2	
9	CP23977	Back-up Ring P-20 T2	1	
10	TQ02016	O-Ring P-20	1	
13	TQ02064	Ram	1	
14	TQ02006	Parallel Key 10 × 8 × 22	1	
15	TP06342	Hex. Socket Head Cap Screw 4 × 10	1	
16	TQ02002	O-Ring P-60 PUR	1	
17	TQ02003	Back-up Ring P-60 T2	1	
18	TQ01999	Bushing	1	
19	TQ02000	O-Ring P-45 PUR	1	
20	TQ02001	Back-up Ring P-45 T2	1	
22	TQ02054	Set Screw	2	
23	TQ02055	Copper Packing 10 × 15	2	
24	TQ02004	Hex. Socket Set Screw with Dog Point 8 × 16	1	
26	TQ01050	Small Hex. Nut M8	2	
27	TQ02304	Hex. Socket Set Screw with Cone Point 8 × 20	2	
28	CP28124	O-Ring P-45	1	
29	TQ02073	Stripper	1	
30	TJ06676	D Punch 22	1	
31	TA99036	Lock Nut Ass'y	1set	
32	(TP07009)	Urethane Washer 31 × 40 × 3.1	1	
33	TJ06677	D Die 22	1	
34	TP05136	Drive Rivet NO.2 × 4.8	4	
35	TQ03225	Plate Model Number	1	
37	TP04154	Hex. Socket Head Cap Screw 4 × 16	4	
67	TQ12338	Washer M4	4	
38	TB08787	Head Cover Ass'y	1set	
39	(TQ12869)	Label Warning	1	
40	(TQ06472)	Label Switch	1	
41	TQ02070	Lock Ring	1	
42	TQ02205	Folding washer	1	
43	TQ02051	Spacer	2	
44	TB04858	Switch Plate Ass'y	1set	
45	(TB01924)	Switch Plate Sub Ass'y	1set	
46	TQ06476	Push Switch MB2011 L/B	2	
47	TQ03338	Hex. Socket Head Cap Screw with spring washer 6 × 18	3	

No.	Parts No.	Description	Qty	Price
48	TQ02044	Distance Collar M6	3	
49	TQ02045	Washer 10 × 18 × 2	3	
50	TQ02038	Grip	1	
51	TQ02046	Grip Sheet	1	
52	TB02389	Metal Consent Cord Ass'y	1set	
53	(TQ02036)	Metal Consent Relay Plug SRCN1A13-5P	1	
54	(TQ02219)	Cord Stopper BS-9	1	
55	TQ02142	Nipple R3/8 × R3/8	2	
56	CA94119	700R-3P Cap Ass'y	1set	
57	CB09136	450B-3P Ass'y	1set	
58	CB09421	450B-3P-D Ass'y	1set	

Accessories

No.	Parts No.	Description	Qty	Price
25	TA92089	Sub Handle Ass'y	1set	
36	TB02230	Chip Guard Ass'y	1set	
59	CA94118	700R-3S Cap Ass'y	2sets	
60	TP05184	Ultra-high Pressure Hose	1	
61	CA96464	3S Cap Ass'y	2sets	
62	CB00126	450B-3S All Ass'y	2sets	
63	TQ02569	High Pressure Hose	1	
64	TB02390	Switch Cord Ass'y	1set	
65	(TQ02568)	Metal Consent Straight Plug SRCN6A13-5P	1	
66	(TQ02567)	Metal Consent Straight Plug SRCN6A13-5S	1	
	TP01939	Hex. Socket Screw Key 4	1	
	TP04004	Hex. Socket Screw Key 5	1	
	TP06012	Spanner	1	
	TP17991	Spanner 12	1	
	TQ07167	Tool Box	1	
	TQ12870	Instruction Manual	1	
	TQ12863	Declaration of Conformity	1	

⚠ WARNING

This diagram is for your reference only. Do not attempt to service or repair the Tool.
 Do not take the Tool apart. Contact an authorized Nitto dealer for all service and repair of the Tool.
 Improper service and repair can cause accidents and service injuries.
 Never attempt to modify the Tool.
 Never attempt service or repair the Tool yourself.

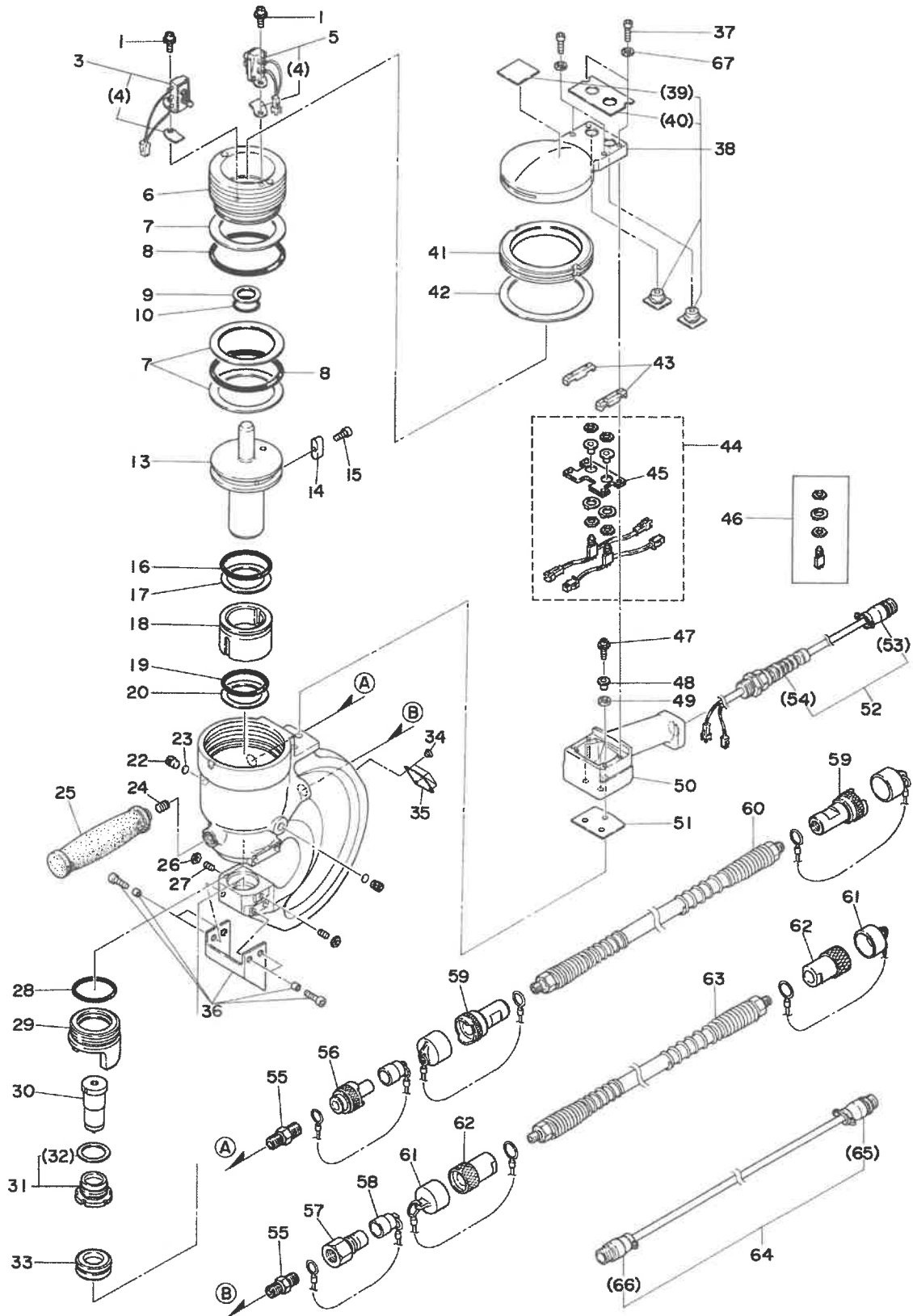

13 HS07-1624, HS11-1624 PARTS LIST

The part numbers with () are included in the Ass'y parts written above them.

No.	Parts No.	Description	Qty	Price
1	TQ03336	Hex. Socket Head Cap Screw with spring washer 6 × 12	2	
3	TB02278	Limit Switch Lower End Ass'y	1set	
4	(TQ02047) (TQ02048)	Shim 1.0 (for Adjustment) Shim 0.5 (for Adjustment)		
5	TB04857	Limit Switch Upper End Ass'y	1set	
6	TQ02014	Cap	1	
7	TQ02015	Back-up Ring P-85 T3	3	
8	TQ02011	O-Ring P-85 PUR	2	
9	CP23977	Back-up Ring P-20 T2	1	
10	TQ02016	O-Ring P-20	1	
13	TQ02005	Ram	1	
14	TQ02006	Parallel Key 10 × 8 × 22	1	
15	TP06342	Hex. Socket Head Cap Screw 4 × 10	1	
16	TQ02002	O-Ring P-60 PUR	1	
17	TQ02003	Back-up Ring P-60 T2	1	
18	TQ01999	Bushing	1	
19	TQ02000	O-Ring P-45 PUR	1	
20	TQ02001	Back-up Ring P-45 T2	1	
22	TQ02054	Set Screw	2	
23	TQ02055	Copper Packing 10 × 15	2	
24	TQ02004	Hex. Socket Set Screw with Dog Point 8 × 16	1	
26	TQ01050	Small Hex. Nut M8	2	
27	TQ02304	Hex. Socket Set Screw with Cone Point 8 × 20	2	
28	CP28124	O-Ring P-45	1	
29	TQ02043	Stripper	1	
30	TJ06676	D Punch 22	1	
31	TA99036	Lock Nut Ass'y	1set	
32	(TP07009)	Urethane Washer 31 × 40 × 3.1	1	
33	TJ06677	D Die 22	1	
34	TP05136	Drive Rivet NO.2 × 4.8	4	
35	TQ03224	Plate Model Number (HS07-1624)	1	
	TQ03226	Plate Model Number (HS11-1624)	1	
37	TP04154	Hex. Socket Head Cap Screw 4 × 16	4	
67	TQ12338	Washer M4	4	
38	TB08788	Head Cover Ass'y	1set	
39	(TQ12869)	Label Warning	1	
40	(TQ06472)	Label Switch	1	
41	TQ02027	Lock Ring	1	
42	TQ02197	Folding washer	1	
43	TQ02051	Spacer	2	
44	TB04858	Switch Plate Ass'y	1set	
45	(TB01924)	Switch Plate Sub Ass'y	1set	

No.	Parts No.	Description	Qty	Price
46	TQ06476	Push Switch MB2011 L/B	2	
47	TQ03338	Hex. Socket Head Cap Screw with spring washer 6 × 18	3	
48	TQ02044	Distance Collar M6	3	
49	TQ02045	Washer 10 × 18 × 2	3	
50	TQ02038	Grip	1	
51	TQ02046	Grip Sheet	1	
52	TB02389	Metal Concent Cord Ass'y	1set	
53	(TQ02036)	Metal Consent Relay Plug SRCN1A13-5P	1	
54	(TQ02219)	Cord Stopper BS-9	1	
55	TQ02142	Nipple R3/8 × R3/8	2	
56	CA94119	700R-3P Cap Ass'y	1set	
57	CB09136	450B-3P Ass'y	1set	
58	CB09421	450B-3P-D Ass'y	1set	

Accessories

No.	Parts No.	Description	Qty	Price
25	TA92089	Sub Handle Ass'y	1set	
36	TB02230	Chip Guard Ass'y	1set	
59	CA94118	700R-3S Cap Ass'y	2sets	
60	TP05184	Ultra-high Pressure Hose	1	
61	CA96464	3S Cap Ass'y	2sets	
62	CB00126	450B-3S All Ass'y	2sets	
63	TQ02569	High Pressure Hose	1	
64	TB02390	Switch Cord Ass'y	1set	
65	(TQ02568)	Metal Concent Straight Plug SRCN6A13-5P	1	
66	(TQ02567)	Metal Concent Straight Plug SRCN6A13-5S	1	
	TP01939	Hex. Socket Screw Key 4	1	
	TP04004	Hex. Socket Screw Key 5	1	
	TP06012	Spanner	1	
	TP17991	Spanner 12	1	
	TQ07167	Tool Box	1	
	TQ12870	Instruction Manual	1	
	TQ12863	Declaration of Conformity	1	

